

# **Unit Price of Low-Voltage Smart Photovoltaic Outdoor Cabinets for Construction Sites**



## Overview

---

The price range for an outdoor energy storage cabinet typically lies between \$3,000 and \$15,000, depending on various factors, such as \*\*1. additional features, and \*\*5. Scope of Application: The Low Voltage PV Grid-Connected Cabinet is specifically designed for distributed photovoltaic (PV) power generation systems. When discussing storage capacity, a. AZE's all-in-one IP55 outdoor battery cabinet system with DC48V/1500W air conditioner is a compact and flexible ESS based on the characteristics of small C&I loads. Sustainable, high-efficiency energy storage solutions.

## Unit Price of Low-Voltage Smart Photovoltaic Outdoor Cabinets for

---



### Outdoor Photovoltaic Energy Cabinet, Base Station Energy Storage

Highjoule's Outdoor Photovoltaic Energy Cabinet and Base Station Energy Storage systems deliver reliable, weather-resistant solar power for telecom, remote sites, and microgrids.

### Outdoor Cabinet Energy Storage System (ESS) for PV Storage

Request quotes, compare prices, and simplify your procurement. Standardized Structure Design: Includes energy storage batteries, power conversion systems (PCS), photovoltaic modules, and ...



### Outdoor Photovoltaic Energy Cabinet

Combines high-voltage lithium battery packs, BMS, fire protection, power distribution, and cooling into a single, modular outdoor cabinet. Uses LiFePO4 batteries with high thermal stability, extensive cycle ...

## PV Grid-Connected Cabinet , Low Voltage Distribution ...

IPKIS offers essential PV grid-connected cabinets. They separate solar generation from the grid, supporting measurement and protection.

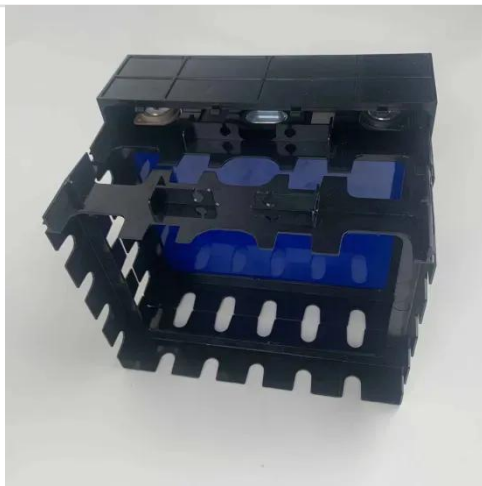

## Solar Battery Cabinet Equipment Enclosures for on-grid or off-grid

The cabinet save time on-site and provide the customer with a neat, safe enclosure for their solar system installation. Our solar battery cabinet systems are storing Pylontech lithium-iron phosphate ...

## IP55/IP65 Outdoor PV Inverter Cabinet with Integrated Distribution

Designed for outdoor deployment, the cabinet features weather-resistant construction, efficient ventilation or air conditioning, and options for battery and DC distribution integration. With robust ...



## How much does an outdoor energy storage cabinet cost?

The price range for an outdoor energy storage cabinet typically lies between

\$3,000 and \$15,000, depending on various factors, such as \*\*1. storage capacity, \*\*2. brand reputation, \*\*3. ...



## Low Voltage PV Grid-Connected Cabinet , manufacturer & price

Professional manufacturer of Low Voltage PV Grid-Connected Cabinets - providing solar power distribution solutions, competitive pricing, and reliable grid-tie systems for commercial & utility-scale ...



 Efficient Higher Revenue

 Intelligent Simple O&M

 Flexible Abundant Configuration

- Max. Efficiency 97.5%
- Max. PV Input Voltage 600V
- 150W Peak Output Power
- 2 MPPT Trackers, 100% DC Input Overvoltage
- Max. PV Input Current 15A, Compatible with High Power Modules
- IP65 Protection Degree, support outdoor installation
- Smart I-V Curve Diagnosis Function: locate PV string faults accurately and automatically detect faults
- DC & AC Type I SPD, prevent lightning damage
- Battery Reverse Connection Protection
- Plug & Play, EPS Switching Under 10ms
- Compatible with Lead-acid and Lithium Batteries
- Max. 6 Units Inverters Parallel
- AFCI Function (Optional): when an arc fault is detected the inverter immediately stops operation

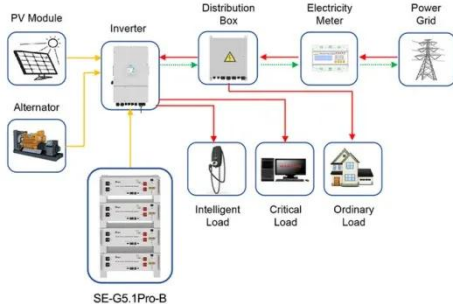

Application scenarios of energy storage battery products

## Breaking Down Photovoltaic Energy Storage Cabinet Costs: What ...

Meet the photovoltaic energy storage cabinet - the unsung hero making solar power work through Netflix binge nights and cloudy days. Let's cut through the industry jargon and explore ...

## Cevain Outdoor Cabinet

The Cevain Outdoor Cabinet System combines solar PV, battery storage, and smart energy management in a single compact unit. Built for outdoor use and

designed to handle harsh ...



---

## Contact Us

For catalog requests, pricing, or partnerships, please visit:  
<https://www.kreatywny-dom.pl>

