

KREATYWNY ENERGY POLSKA

Solar Base Station Lead-Acid Battery Effect



Overview

Lead-acid solar batteries store energy through chemical reactions between lead, water, and sulfuric acid. These reactions convert stored chemical energy into electrical energy, enabling the batteries to power devices or store excess energy from solar panels. Proven Reliability: With over a century of use, lead acid batteries offer reliability and extensive industry knowledge in energy storage. In this chapter the solar photovoltaic system designer can obtain a brief summary of the electrochemical reactions in an operating lead-acid battery, various construction types, operating characteristics, design and operating procedures controlling life of the battery, and maintenance and safety. Battery storage is a technology that enables power system operators and utilities to store energy for later use. However, as with all technologies, they come with a blend of benefits and drawbacks. Understanding these pros and cons is essential if you're considering lead-acid batteries for your solar setup.

Solar Base Station Lead-Acid Battery Effect



Application scenarios of energy storage battery products

Grid-Scale Battery Storage: Frequently Asked Questions

Increasing needs for system flexibility, combined with rapid decreases in the costs of battery technology, have enabled BESS to play an increasing role in the power system in recent years.

Lead-acid batteries: types, advantages and disadvantages

In summary, lead-acid batteries are a solid and reliable option for energy storage in photovoltaic systems. Their affordable cost, durability and availability make them attractive for a wide ...

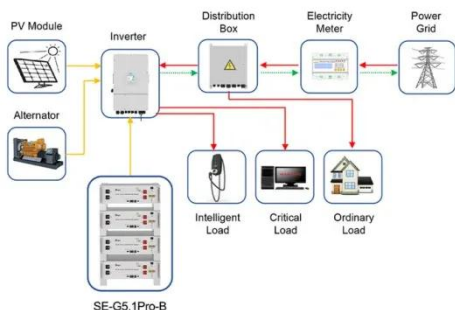

Application scenarios of energy storage battery products

Should You Choose A Lead Acid Battery For Solar Storage?

How A Lead Acid Battery Works
Automotive Batteries vs Deep Cycle Batteries
Different Types of Deep Cycle Lead Acid Batteries For Solar
Are Lead Acid Batteries Better Than Lithium Ion Batteries?
The short answer to this question is no, lead acid batteries are not better than lithium ion batteries. It is worth noting, however, that lithium ion is a newer battery technology that has

specific advantages over lead acid, including: 1. Greater energy density (more energy in a smaller space) 2. Higher tolerance for temperature changes 3. The abil See more on solarreviews batteriesforsolar

The Pros and Cons of Lead-Acid Solar Batteries: What You Need to ...

See More

Lead-acid batteries, a time-tested technology, have been pivotal in storing solar energy for later use. However, as with all technologies, they come with a blend of benefits and drawbacks. Understanding ...

Lead-acid Solar Batteries: Definition, How it Works, and Different Types

Lead-acid solar batteries store energy through chemical reactions between lead, water, and sulfuric acid. These reactions convert stored chemical energy into electrical energy, enabling the ...



The Pros and Cons of Lead-Acid Solar Batteries: What You Need to ...

Lead-acid batteries, a time-tested technology, have been pivotal in storing



solar energy for later use. However, as with all technologies, they come with a blend of benefits and drawbacks. Understanding ...

Pros and Cons of Using Lead-Acid Batteries for Solar Power Systems

A typical lead-acid battery used in a solar system might have a capacity of 100 Ah or more. The battery must be charged properly to ensure it operates efficiently and lasts as long as ...



Lead-acid Batteries in Solar Power Systems

Lead-acid batteries are a crucial component of solar power systems, storing the energy generated by photovoltaic panels during daylight hours and supplying power to the grid or loads ...

Comprehensive Guide to Solar Lead Acid Batteries: Selection, Usage, ...

When choosing a solar lead acid battery for your solar power system, there are a few crucial factors to consider. These

factors will help you determine the right battery for your needs and ...



Can You Use Lead Acid Batteries for Solar: Benefits, Drawbacks, and

Discover whether lead acid batteries are a viable choice for solar energy storage. This article explores the pros and cons of lead acid batteries, detailing their cost-effectiveness, reliability, ...



Should You Choose A Lead Acid Battery For Solar Storage?

Lead acid batteries are proven energy storage technology, but they're relatively big and heavy for how much energy they can store. Deep cycle lithium ion batteries are more expensive than nearly all lead ...



HANDBOOK OF SECONDARY STORAGE BATTERIES CHAP ...

Figure 3-6 shows the effect of operating temperature on discharge capacity for three electrolyte gravities in a lead-



calcium battery selected for a solar photovoltaic system.

Contact Us

For catalog requests, pricing, or partnerships, please visit:
<https://www.kreatywny-dom.pl>

